

Pneumatic Rack & Pinion Actuator

FNW[™]



STANDARD FEATURES

Torque output range from 40 to 32,315 inch-pounds depending on air supply pressure and/or spring sets. Max pressure rating of 120 PSI. Standard temperature range is -4°F to 185°F with Buna seals (-40°F to 350°F available with Viton®).

ACCESSORY MOUNTING

The actuator's accessory mounting pad meets international NAMUR and ISO standards that match accessories such as limit switches, positioners, and position monitors with NAMUR shafts. This makes mounting of accessories economical and quick.

POSITION INDICATOR

Low profile position indicator also acts as the cam for the actuator stop adjustments and still leaves room for mounting accessories. Designed to fit NAMUR shaft accessories.

TRAVEL STOPS

Dual travel stops located on the actuator body provide +/- 5° of travel adjustment for models 52 to 125. Stops are not located in the pressure containing body of the actuator, reducing the number of possible leak paths and necessary seals.

END CAPS

End caps are die cast aluminum coated with corrosion resistant stainless steel impregnated epoxy (anodized aluminum models have poly-powder coat) and are secured with full length stainless steel bolts. Double-acting and spring-return actuators utilize the same end caps allowing quick conversion by adding or removing springs as needed.

PINION

The pinion is ground from hardened steel then nickel plated for maximum corrosion and wear resistance.

SOLENOID MOUNTING

The FNW actuator is designed with an international NAMUR solenoid bolt pattern that allows for direct mounting of NAMUR style solenoids. This configuration eliminates the need for costly pipe nipples, tubing, and mounting brackets.

VALVE MOUNTING

The FNW actuator is designed for direct mounting to many FNW valves using ISO 5211 bolt patterns and 8-point female drive.

ACTUATOR BODY

The actuator body is made from extruded aluminum and coated with a nickel plated exterior (standard) for increased corrosion resistance (actuator is also available in hard anodized aluminum).

PISTON GUIDES

Large self lubricating PTFE piston thrust blocks and anti-friction rings are designed to reduce internal actuator friction and maintain piston thrust stability. Lower friction means more torque output vs. supply pressure.

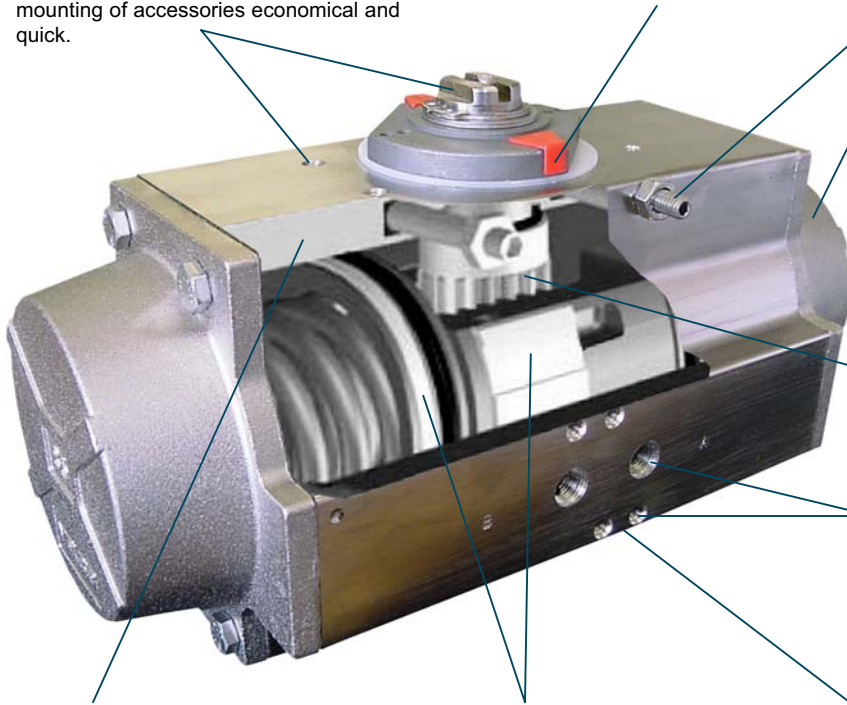

Spring-Return Spring Set Configurations*

Model 52 to 140

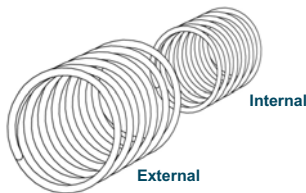

Spring Set	External	Internal
1	1	1
2	2	-
3	1	2
4	2	1
5	2	2

Model 160 and 200

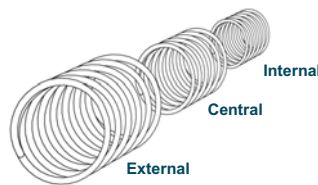

Spring Set	External	Central	Internal
1	-	2	-
2	2	-	-
3	1	2	-
4	2	-	2
5	2	2	-
6	2	2	2

Model 270

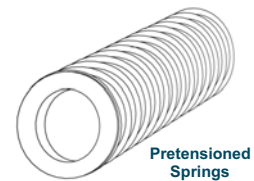

Spring Set	Springs Per Side
1	2/3
2	3/3
3	3/4
4	4/4
5	4/5
6	5/5
7	5/6
8	6/6

* Note: FNW actuators are stocked with full spring sets (models 52 to 140 have spring set 5, models 160 to 200 have spring set 6, and model 270 has spring set 8). Spring sets are reconfigurable. See torque sheets for ranges.

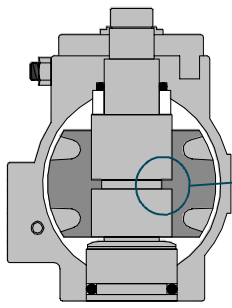

Anti-Blowout Pinion

Many rack and pinion actuator designs usually rely exclusively upon c-rings or spiral retainers to hold the pinion in place. If these devices weaken or break off, the pinion can blow out the bottom of the actuator. Our grooved pinion and rack design creates an added mechanical hold to keep the pinion from blowing out the bottom of the actuator. In addition, the groove keeps the piston on track during the stroke and helps eliminate side loading.

Standard Operation

Double-Acting

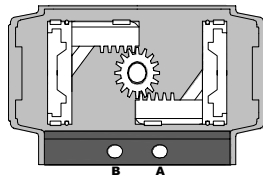
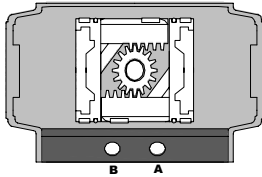

For counterclockwise output rotation (typically valve opening), apply supply pressure to port A, driving the pistons apart, exhausting air from port B. Supply pressure to port B, port A exhausting, will drive the pistons in for clockwise rotation.

Spring-Return

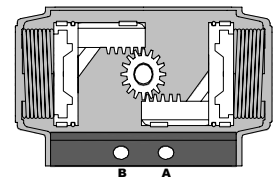
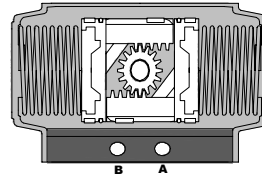

For counterclockwise output rotation (typically valve opening), apply supply pressure to port A, driving the pistons apart, compressing the springs, exhausting air from port B. Spring force rotates the actuator clockwise when supply pressure to port A is exhausted.

Reversible Operation

Standard CCW Rotation

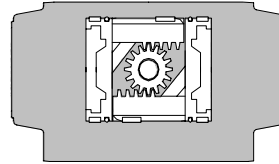
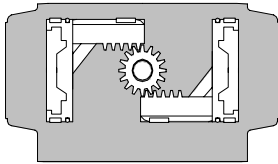

Reversed CW Rotation

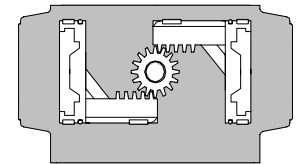
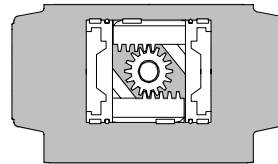

The standard action of the FNW Valve actuator is CCW to open and CW to close for typical valves. This action is field reversible for CW to open and CCW to close (typically for fail open spring-return applications).

Standard Materials



- Housing – Nickel plated extruded aluminum (also in hard anodized aluminum)
- Anti-Blowout Pinion – steel (nickel plated)
- Lower Pinion O-ring - NBR 70
- Upper Pinion O-ring – NBR70
- Pinion Spacer Bearing – PTFE (15% Graphite)
- Cam Spacer Ring – PTFE (15% Graphite)
- Position Indicator Cam – Stainless steel
- Position Indicator – Nylon
- Pinion Washer – Stainless steel
- Pistons – Die cast aluminum
- Piston O-ring Bushing – NBR 70

- Piston Antifriction Ring – PTFE (15% Graphite)
- Piston Thrust Block – PTFE (15% Graphite)
- Stop Bolt Nut – Stainless steel
- Stop Bolt – Stainless steel
- End Caps – Die cast aluminum coated with stainless steel impregnated epoxy (anodized aluminum models have poly-powder coat finish)
- End Cap Seals – NBR
- End Cap Bolts – Stainless steel
- Springs – Zinc phosphate coated steel (spring return units only)

Spring-Return Actuator Torques (In-Lbs)

Model	Spring Set*	Spring Stroke		Air Stroke							
		Start	End	40 PSI		60 PSI		80 PSI		100 PSI	
				Start	End	Start	End	Start	End	Start	End
52	-1	44	32	48	23	95	70				
	-2	59	42			84	54				
	-3	66	46			80	47	127	94		
	-4	82	57			70	31	116	78	163	125
	-5	105	72					101	55	148	102
63	-1	85	44	92	38	176	122				
	-2	109	58			162	98				
	-3	128	71			149	79	233	162		
	-4	152	85			136	54	219	138	303	222
	-5	196	111					193	95	276	178
75	-1	172	89	168	63	319	214				
	-2	226	118			291	160				
	-3	249	133			275	137	426	288		
	-4	303	162			247	83	398	234	549	385
	-5	380	205					354	157	505	308
85	-1	242	143	238	109	460	330				
	-2	298	176			427	274				
	-3	361	215			387	211	609	432		
	-4	417	248			354	155	576	376	797	633
	-5	536	321					503	257	725	478
100	-1	395	218	384	154	728	499				
	-2	521	288			658	372				
	-3	564	318			628	329	973	674		
	-4	691	389			558	203	903	548	1248	893
	-5	860	489					802	378	1147	723
115	-1	658	363	650	270	1220	840				
	-2	835	449			1133	663				
	-3	957	538			1044	541	1615	1112		
	-4	1133	625			958	365	1528	935	2098	1505
	-5	1432	800					1352	637	1923	1207
125	-1	877	470	850	328	1599	1077				
	-2	1040	560			1509	914				
	-3	1313	718			1351	640	2099	1389		
	-4	1477	808			1261	477	2010	1226	2758	1974
	-5	1913	1055					1762	789	2511	1538
140	-1	1346	726	1240	508	2244	1512				
	-2	1523	815			2144	1323				
	-3	1958	1036			1910	856	2914	1861		
	-4	2126	1134			1810	668	2814	1672	3810	2668
	-5	2728	1453					2481	1017	3477	2013
160	-1	1345	885	1921	1390						
	-2	1991	1301			2952	2217				
	-3	2336	1531			2713	1854				
	-4	2841	1770			2447	1350	3886	2779		
	-5	3327	2230					3452	2240		
	-6	4186	2655					2983	1443	4421	2828
200	-1	2168	1540	3718	2904						
	-2	3150	2186			5770	4681				
	-3	3752	2637			5301	4035				
	-4	4699	3124			4788	3080	7486	5795		
	-5	5327	3726					6822	5008		
	-6	6867	4664					5893	3539	8591	6175
270	-1	6973	4469	8574	6017	15309	12743				
	-2	8372	5363	7619	4548	14353	11283				
	-3	9761	6257	6672	3088	13398	9814				
	-4	11159	7150	5716	1619	12442	8353	19177	15080		
	-5	12549	8044			11495	6884	18221	13619		
	-6	13947	8938			10539	5415	17274	12150		
	-7	15336	9832			9584	3955	16319	10681	23053	17416
	-8	16735	10735			8637	2486	15363	9221	22098	15947

* Note: FNW actuators are stocked with full spring sets (models 52 to 140 have spring set 5, models 160 to 200 have spring set 6, and model 270 has spring set 8).

Double-Acting Actuator Torques (In-Lbs)

Model	Air Stroke						
	40 PSI	50 PSI	60 PSI	70 PSI	80 PSI	90 PSI	100 PSI
52	86	110	133	156	179	203	226
63	154	196	238	280	321	363	405
75	284	360	435	511	586	661	737
85	408	518	629	740	851	962	1072
100	646	818	991	1163	1336	1508	1681
115	1070	1355	1640	1925	2210	2495	2780
125	1409	1783	2157	2532	2906	3280	3654
140	2009	2511	3013	3515	4018	4513	5015
160	2930	3662	4394	5127	5859	6591	7324
200	5488	6866	8239	9612	10981	12359	13732
270	12734	15919	19097	22284	25469	28654	31832

Actuator Weight (Lbs.)

Model	52	63	75	85	100	115	125	140	160	200	270
Double Acting	2.25	3.26	5.51	7.39	11.02	17.75	22.09	33.86	43.21	70.99	154.00
Spring Return	2.62	3.97	6.94	9.73	14.40	23.92	26.76	45.28	65.04	111.00	192.79

Actuator Air Consumption Per Stroke (Cubic Inches)

Action	Model										
	52	63	75	85	100	115	125	140	160	200	270
CCW (DA)	6.10	11.60	21.97	31.12	48.21	78.72	99.47	137.91	220.30	347.84	915.36
CW (DA)	7.93	14.04	26.85	39.06	61.02	104.35	134.86	192.84	290.47	599.86	1086.22
CW (SR)	6.71	11.60	21.97	32.34	48.82	84.21	108.62	146.46	214.8	462.56	945.87

Actuator Stroke Speed (Seconds)*

Action	Model										
	52	63	75	85	100	115	125	140	160	200	270
CCW (DA)	0.03	0.06	0.12	0.20	0.30	0.53	0.83	0.98	1.15	1.74	4.50
CW (DA)	0.04	0.08	0.12	0.19	0.27	0.47	0.66	0.93	1.10	1.70	4.50
CCW (SR)	0.09	0.14	0.22	0.31	0.44	0.83	1.08	1.23	1.75	2.38	4.50
CW (SR)	0.09	0.14	0.22	0.33	0.46	0.78	0.90	0.97	1.34	2.19	6.20

* Note: Stroke speeds listed above are based on actuator alone with 80 PSI supply air. Valve torques and flow characteristics of actuator control accessories will have an affect on overall speed.

Dimensional Drawings - Model 52 to 140

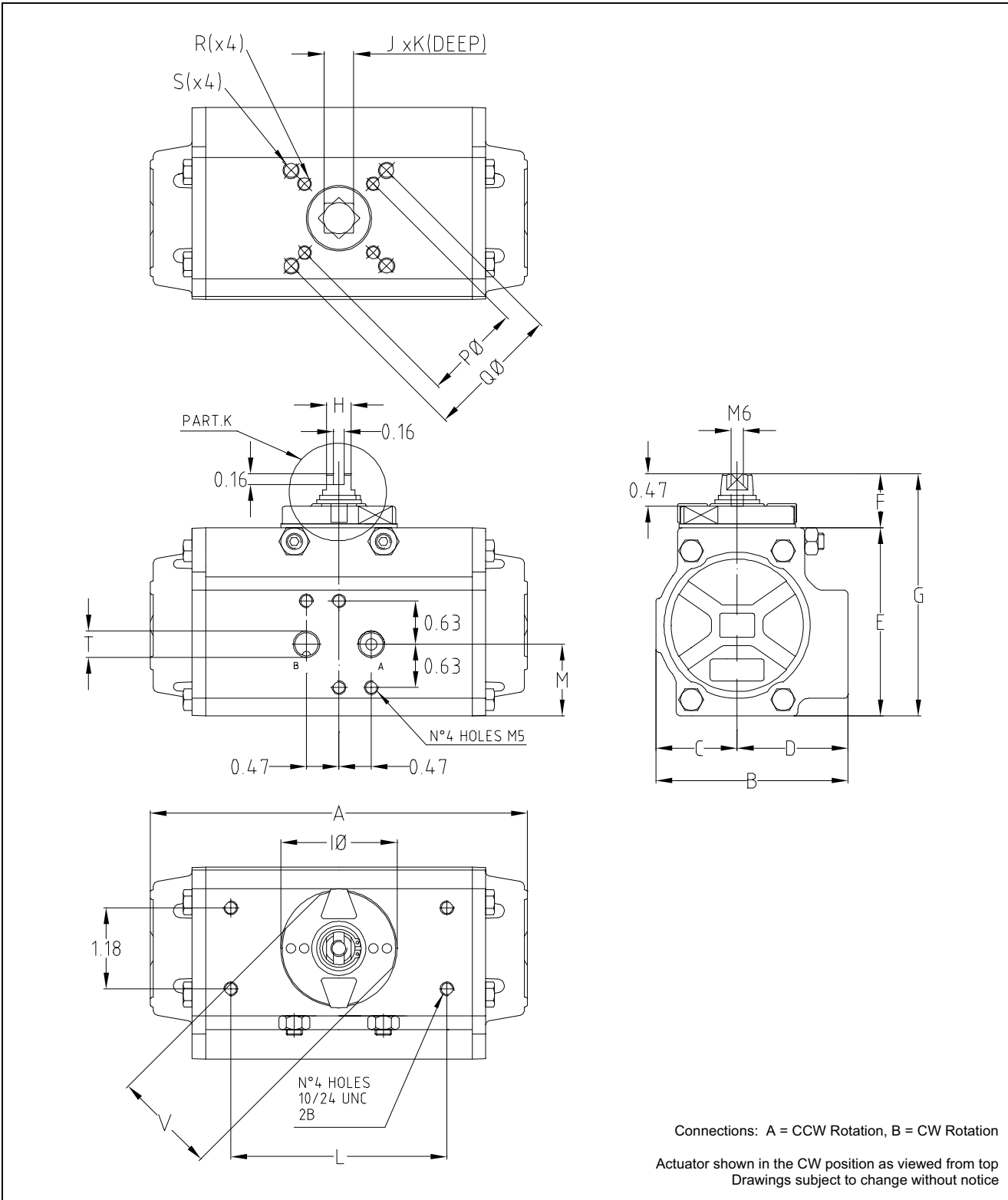

Dimensions (Inches) - Model 52 to 140

Mod.	Mtg ISO 5211	A	B	C	D	E	F	G	H	IØ	J	K	L	M	PØ	QØ	R (UNC)	S (UNC)	T (NPT)	V
52	F03/F05	5.49	2.80	1.2	1.6	2.74	0.79	3.52	0.35	1.65	0.43	0.47	3.14	1.04	1.42	1.97	10-24	1/4-20	1/8	1.50
63	F05/F07	6.37	3.2	1.40	1.8	3.17	0.79	3.96	0.43	1.89	0.55	0.63	3.14	1.08	1.97	2.76	1/4-20	5/16-18	1/8	1.61
75	F05/F07	8.15	3.72	1.65	2.07	3.82	0.79	4.61	0.51	2.40	0.67	0.75	3.14	1.38	1.97	2.76	1/4-20	5/16-18	1/8	1.97
85	F05/F07	9.35	4.17	1.87	2.30	4.27	0.79	5.06	0.59	2.40	0.67	0.75	3.14	1.65	1.97	2.76	1/4-20	5/16-18	1/8	1.97
100	F07/F10	10.69	4.84	2.17	2.68	4.78	0.79	5.57	0.59	2.40	0.67	0.81	3.14	1.97	2.76	4.02	5/16-18	3/8-16	1/4	1.97
115	F07/F10	12.91	5.39	2.52	2.87	5.57	1.18	6.75	0.87	3.31	0.87	0.94	5.12	1.97	2.76	4.02	5/16-18	3/8-16	1/4	-
125	F07/F10	14.41	5.83	2.68	3.15	6.04	1.18	7.22	0.87	3.31	0.87	0.94	5.12	2.40	2.76	4.02	5/16-18	3/8-16	1/4	-
140	F10/F12	16.85	6.46	3.01	3.44	6.93	1.18	8.11	0.94	3.46	1.06	1.14	5.12	2.80	4.02	4.92	3/8-16	1/2-13	1/4	-

Dimensional Drawings - Model 160 to 270

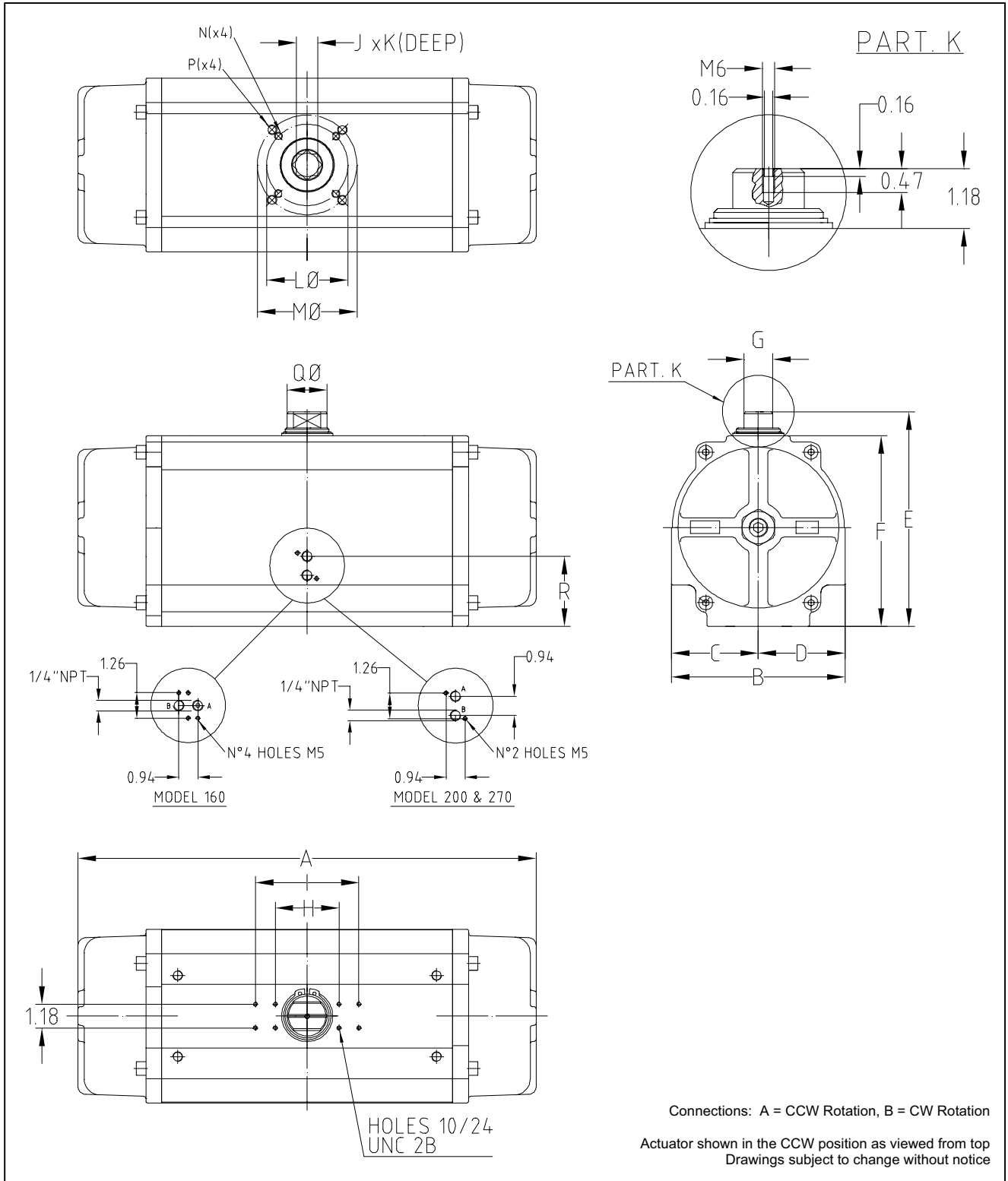

Dimensions (Inches) - Model 160 to 270

Mod.	Mtg ISO 5211	A	B	C	D	E	F	G	H	I	J	K	LØ	MØ	N (UNC)	P (UNC)	QØ	R
160	F10/F12	20.55	7.36	3.43	3.94	8.58	7.40	1.18	3.15	5.12	1.06	1.26	4.02	4.92	3/8-16	1/2-13	1.38	3.21
200	F14	22.64	8.58	4.29	4.29	10.59	9.41	1.42	3.15	5.12	1.42	1.54	-	5.51	-	5/8-11	1.97	3.46
270	F16	26.46	11.42	5.71	5.71	14.21	13.03	1.42	3.15	5.12	1.81*	2.05	-	6.50	-	3/4-10	1.97	4.76

* Note: Only with square connection at 45°.



Pneumatic Rack & Pinion Actuator

DOC: FNWNBG07 Ver. 5/07

© 2007 - FNW. All rights reserved.
The FNW logo is a registered trademark of Ferguson Enterprises, Inc.

The contents of this publication are presented for information purposes only, and while effort has been made to ensure their accuracy, they are not to be construed as warranties or guarantees, expressed or implied, regarding the products or services described herein or their use or applicability. All sales are governed by our terms and conditions, which are available on request. We reserve the right to modify or improve the designs or specifications of our products at any time without notice. Always verify that you have the most recent product specifications or other documentation prior to the installation of these products.