

150# IPS DUCTILE IRON BACK-UP FLANGES

Features:

- 150# Drilling
- IPS Sizes
- Finishes:
 - Red Primer Painted
 - Hot Dipped Galvanized
- Types:
 - Stub End (SE) - 1/2" to 36"
 - Angle Face Ring (AFR) - 1" to 36"
- Light Weight Pattern

Material:

- ASTM A536 grade 65-45-12

Physical Properties (Min.):

- Tensile Strength: 65,000 PSI
- Yield Strength: 45,000 PSI
- Elongation: 12%

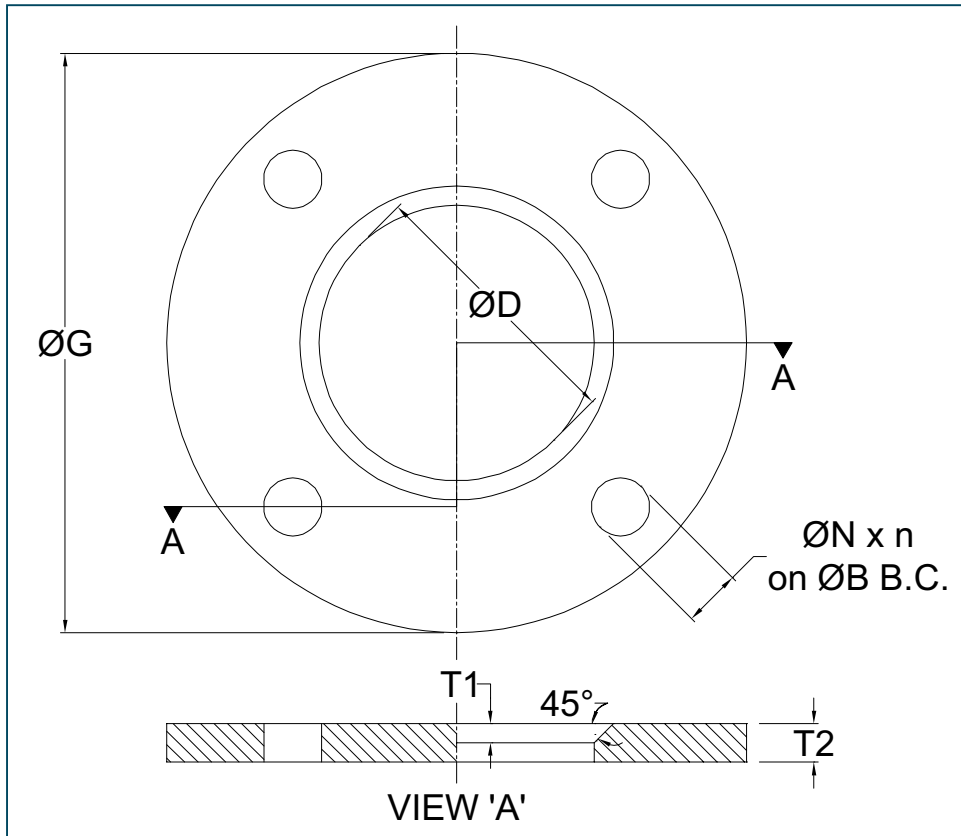

Figure Number Matrix **

FNW FINISH DI TYPE BUF IPS SIZE					
FINISH		TYPE		SIZE CODES	
RED PRIMER = P	STUB END = BLANK	1/2 = D	2-1/2 = L	8 = X	18 = 18
GALVANIZED = G	ANGLE FACE RING = AFR	3/4 = F	3 = M	10 = 10	20 = 20
		1 = G	4 = P	12 = 12	24 = 24
		1-1/2 = J	5 = S	14 = 14	30 = 30
		2 = K	6 = U	16 = 16	36 = 36

**** Note: Not all configurations of model numbers are available. Consult your supplier on specific material, rating, and size combinations.**

150# IPS DUCTILE IRON BACK-UP FLANGES



Size	ØD (IPS)		ØG ± 0.118	T1	T2	T2 Tolerance	ØB ± 0.059	ØN ± 0.079	n	Wt. (Lbs.)
	SE ± 0.079	AFR ± 0.079								
1/2	0.900	-	3.50	0.25	0.500	± 0.079	2.375	0.625	4	-
3/4	1.110	-	3.88	0.25	0.500	± 0.079	2.750	0.625	4	-
1	1.375	1.750	4.25	0.25	0.500	± 0.079	3.125	0.625	4	1.1
1-1/2	1.969	2.375	5.00	0.25	0.500	± 0.079	3.875	0.625	4	1.7
2	2.437	2.750	6.00	0.25	0.500	± 0.079	4.750	0.750	4	2.9
2-1/2	2.937	3.250	7.00	0.25	0.500	± 0.079	5.500	0.750	4	3.8
3	3.563	4.000	7.50	0.25	0.500	± 0.079	6.000	0.750	4	4
4	4.563	5.125	9.00	0.25	0.500	± 0.079	7.500	0.750	8	5.3
5	5.625	6.063	10.00	0.25	0.500	± 0.079	8.500	0.875	8	7
6	6.750	7.250	11.00	0.25	0.625	± 0.079	9.500	0.875	8	8
8	8.750	9.375	13.50	0.25	0.625	± 0.079	11.750	0.875	8	11.4
10	10.875	11.375	16.00	0.25	0.625	± 0.079	14.250	1.000	12	14.1
12	12.875	13.625	19.00	0.25	0.750	± 0.079	17.000	1.000	12	23.8
14	14.187	14.750	21.00	0.25	0.750	± 0.118	18.750	1.125	12	30.9
16	16.187	16.437	23.50	0.25	0.750	± 0.118	21.250	1.125	16	40
18	18.187	18.750	25.00	0.25	0.750	± 0.118	22.750	1.125	16	43.5
20	20.250	20.750	27.50	0.25	0.875	± 0.118	25.000	1.125	20	53
24	24.250	24.750	32.00	0.25	1.000	± 0.157	29.500	1.375	20	80
30	30.375	30.875	38.75	0.25	1.000	± 0.157	36.000	1.375	28	104
36	36.500	36.875	45.50	0.25	1.125	± 0.157	42.750	1.625	32	150

DOC: FNWDIBUF08 Ver. 2/08

© 2008 - FNW. All rights reserved.
The FNW logo is a registered trademark of Ferguson Enterprises, Inc.

The contents of this publication are presented for information purposes only, and while effort has been made to ensure their accuracy, they are not to be construed as warranties or guarantees, expressed or implied, regarding the products or services described herein or their use or applicability. All sales are governed by our terms and conditions, which are available on request. We reserve the right to modify or improve the designs or specifications of our products at any time without notice. Always verify that you have the most recent product specifications or other documentation prior to the installation of these products.