

## 300# Carbon Steel OS&Y Gate Valve

### Standard Materials

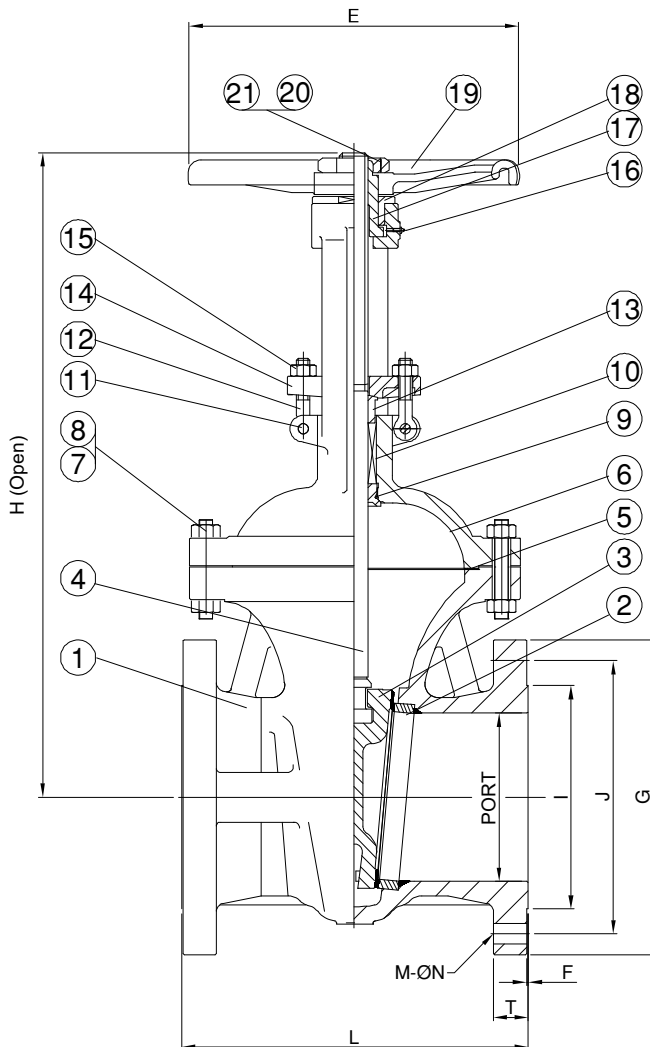

NO	PART NAME	MATERIAL
1	Body	ASTM A216 Gr. WCB
2	Seat Ring	ASTM A105 + Hard Faced
3	Disc	ASTM A216 Gr. WCB + 13% CR Faced
4	Stem	ASTM A182 F6
5	Gasket	Soft Iron + Graphite
6	Bonnet	ASTM A216 Gr. WCB
7	Bonnet Bolt Nut	ASTM A194 Gr. 2H
8	Bonnet Bolt	ASTM A193 Gr. B7
9	Bonnet Bushing	ASTM A276 Type 410
10	Gland Packing	Braided Graphite + DF Graphite Ring
11	Eye Bolt Pins	Carbon Steel
12	Gland Eye Bolts	ASTM A193 Gr. B7
13	Gland	ASTM A276 Type 410
14	Gland Flange	ASTM A216 Gr. WCB
15	Eye Bolt Nut	ASTM A194 Gr. 2H
16	Grease Nipple	Carbon Steel
17	Yoke Sleeve	ASTM A439 Gr. D-2
18	Retaining Nut	Carbon Steel
19	Handwheel	Malleable Iron
20	Screw	Carbon Steel
21	Handwheel Nut	Carbon Steel

NOTES:  
 Design per API 600  
 Pressure/Temperature Rating per ANSI B16.34  
 Flange Dimensions per ANSI B16.5  
 Face to Face Dimensions per ANSI B16.10  
 Pressure Tested per API 598

### Dimensions (Inches)

SIZE	2"	2-1/2"	3"	4"	6"	8"	10"	12"	14"	16"	18"	20"	24"
Port	1.969	2.559	3.150	3.937	5.906	7.874	9.843	11.811	13.779	15.748	17.716	19.685	23.622
L	8.504	9.488	11.142	12.008	15.866	16.496	17.992	19.764	30.000	32.992	35.984	39.016	45.000
H	16.614	20.157	20.551	24.213	31.654	39.449	48.386	59.528	64.764	72.480	76.496	84.803	100.512
E	7.874	7.874	9.843	11.811	13.780	15.748	17.717	19.685	23.622	-	-	-	-
Flange Dimensions	F	0.06	0.06	0.06	0.06	0.06	0.06	0.06	0.06	0.06	0.06	0.06	0.06
	G	6.50	7.50	8.25	10.00	12.50	15.00	17.50	20.50	23.00	25.50	28.00	30.50
	I	3.62	4.12	5.00	6.19	8.50	10.62	12.75	15.00	16.25	18.50	21.00	23.00
	J	5.00	5.88	6.62	7.88	10.62	13.00	15.25	17.75	20.25	22.50	24.75	27.00
	T	0.88	1.00	1.12	1.25	1.44	1.62	1.88	2.00	2.12	2.25	2.38	2.50
	M	8	8	8	8	12	12	16	16	20	20	24	24
	N	0.75	0.88	0.88	0.88	0.88	1.00	1.12	1.25	1.25	1.38	1.38	1.38
Wt. (LBS)	53	97	115	168	322	481	776	1041	1734	2227	2657	3792	5765

\* 16" & Larger Valves include Gear Operator