

2 PC FULL PORT 400 WOG PUMP ISOLATION VALVE

Features:

- 400 WOG
- Full Port
- Flanged Pump Connection
 - by NPT End (Fig. 470)
 - by Sweat End (Fig. 475)
- Integral Flange (no added parts)
- Blow Out Proof Stem
- Adjustable Packing
- Forged Brass Body & End Cap
- Includes T-handle, Gasket, and Hardware



Fig. 470 - FNPT



Fig. 475 - Sweat



Includes T-handle, Gasket, and Hardware

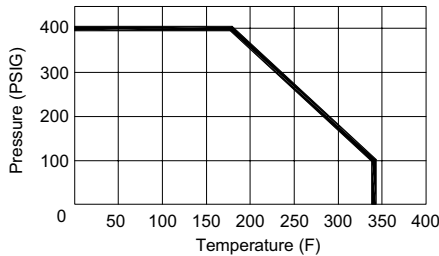

The FNW 470 (NPT connection) and 475 (Sweat end connection) pump isolation valve decreases installation time and the number of possible leak paths by its integral pump flange connection. Pump isolation valves make pump servicing easier by isolating the pump and providing ease of disconnect for pump removal.

Weights

Size	Wt. (Lbs)	
	Fig 470	Fig 475
3/4	1.72	1.71
1	1.82	1.77
1-1/4	2.08	2.08
1-1/2	2.60	2.66

Figure Number Matrix

F N W 4 7 END X		
END TYPE	SIZE CODES	
0 = NPT ENDS	3/4 = F	1-1/4 = H
5 = SWEAT ENDS	1 = G	1-1/2 = J

For other valve materials or configurations, contact FNW Valve at (503) 287-8383 for sales assistance.

2 PC FULL PORT 400 WOG PUMP ISOLATION VALVE

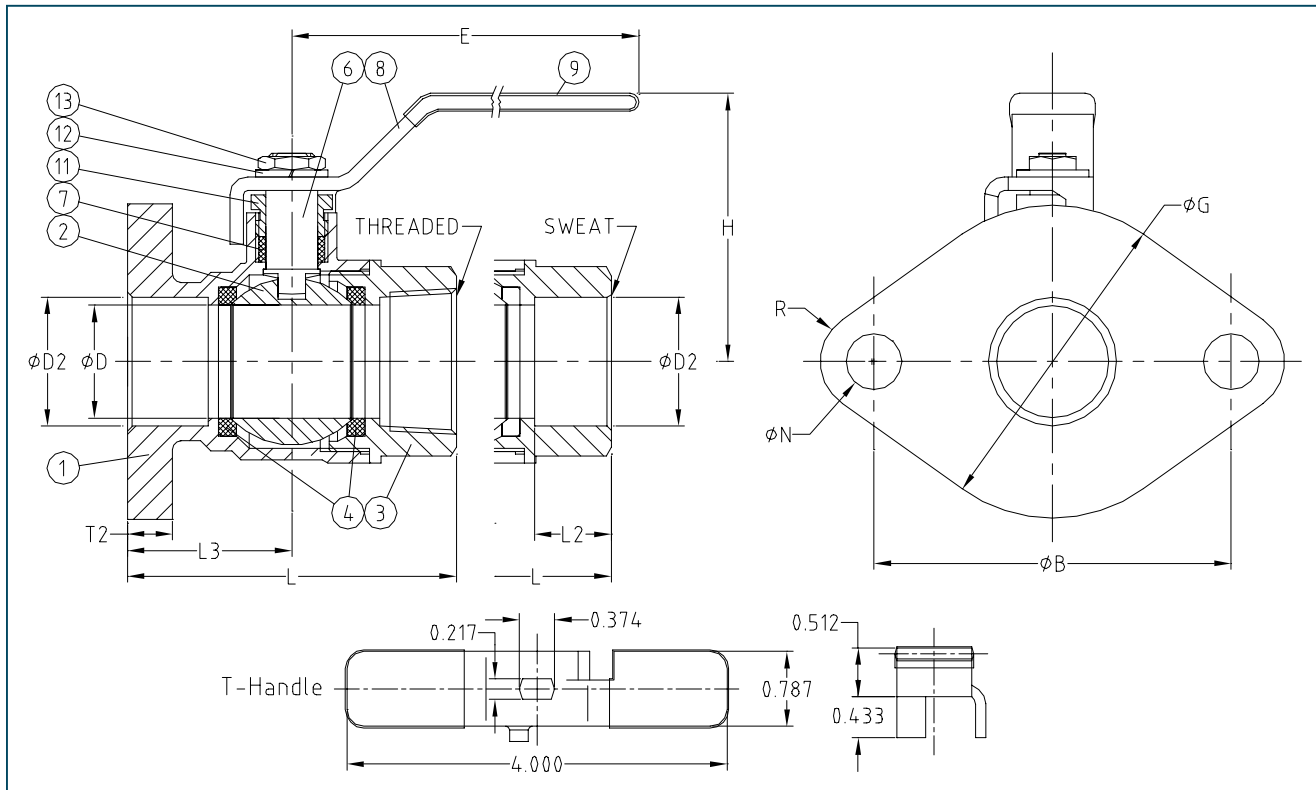

Dimensions (Inches)

Size	ØB	ØD	ØD2	Threaded Dimensions	E	ØG	H	L		L1	L2	L3	ØN	R	T2
								470	475						
3/4	3.150	0.748	0.878	3/4" - 14 NPT	4.331	2.756	2.382	2.421	2.618	1.220	0.75	1.22	0.492	0.453	0.394
1	3.150	0.984	1.126	1" - 11-1/2 NPT	4.331	2.756	2.559	2.815	3.071	1.378	0.87	1.38	0.492	0.453	0.394
1-1/4	3.150	1.142	1.378	1-1/4" - 11-1/2 NPT	4.331	2.756	2.717	3.090	3.543	1.535	1.10	1.54	0.492	0.453	0.394
1-1/2	3.150	1.457	1.628	1-1/2" - 11-1/2 NPT	4.331	2.756	2.913	3.465	3.917	1.732	1.10	1.73	0.492	0.453	0.394

Standard Materials

Ref. No.	Description	Material	Qty	Ref. No.	Description	Material	Qty	Remarks
1	Body	Brass - C37700	1	11	Gland Nut	Brass - C36000	1	
2	Ball	Brass - C37700	1	12	Handle Washer	ASTM G1566	1	
3	End Cap	Brass - C37700	1	13	Handle Nut	Steel - AISI-1010	1	
4	Seat	PTFE	2	14	Flange Bolt	Steel - AISI-1010	2	Not shown
6	Stem	Brass - C36000	1	15	Flange Nut	Steel - AISI-1010	2	Not shown
7	Stem Packing	PTFE	1	16	Flange Gasket	Rubber - NBR	1	Not shown
8	Handle	Steel - AISI-1010	1	17	T-Handle	Steel - AISI-1010	1	
9	Handle Cover	Plastic	1					

DOC: FNWBVPI07 Ver. 5/07

© 2007 - FNW. All rights reserved.
The FNW logo is a registered trademark of Ferguson Enterprises, Inc.

The contents of this publication are presented for information purposes only, and while effort has been made to ensure their accuracy, they are not to be construed as warranties or guarantees, expressed or implied, regarding the products or services described herein or their use or applicability. All sales are governed by our terms and conditions, which are available on request. We reserve the right to modify or improve the designs or specifications of our products at any time without notice. Always verify that you have the most recent product specifications or other documentation prior to the installation of these products.