

Figure 400 BRASS BODY BALL VALVES



2 PC FULL PORT 600 WOG w/THREADED ENDS

Features:

- 600 WOG
- 150 WSP
- Full Port
- Meets NSF-61 Standards
- Meets MSS SP-110 Standards
- Blow-out Proof Stem
- Double O-ring Stem Packing
- Threaded Ends (ANSI B1.20.1)
- Forged Brass Body & End Cap
- 100% Electronically Tested in Open and Closed Position at 80 PSI
- Optional Slide Lock Lever Meets OSHA 1910.147
- Uses The Same Handle Accessories As The Figure 420 Ball Valve



OPTIONS



Lock Lever



Stem Extension



Tee or Oval Handle



Memory Stop

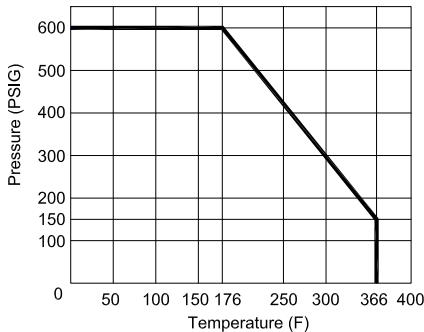
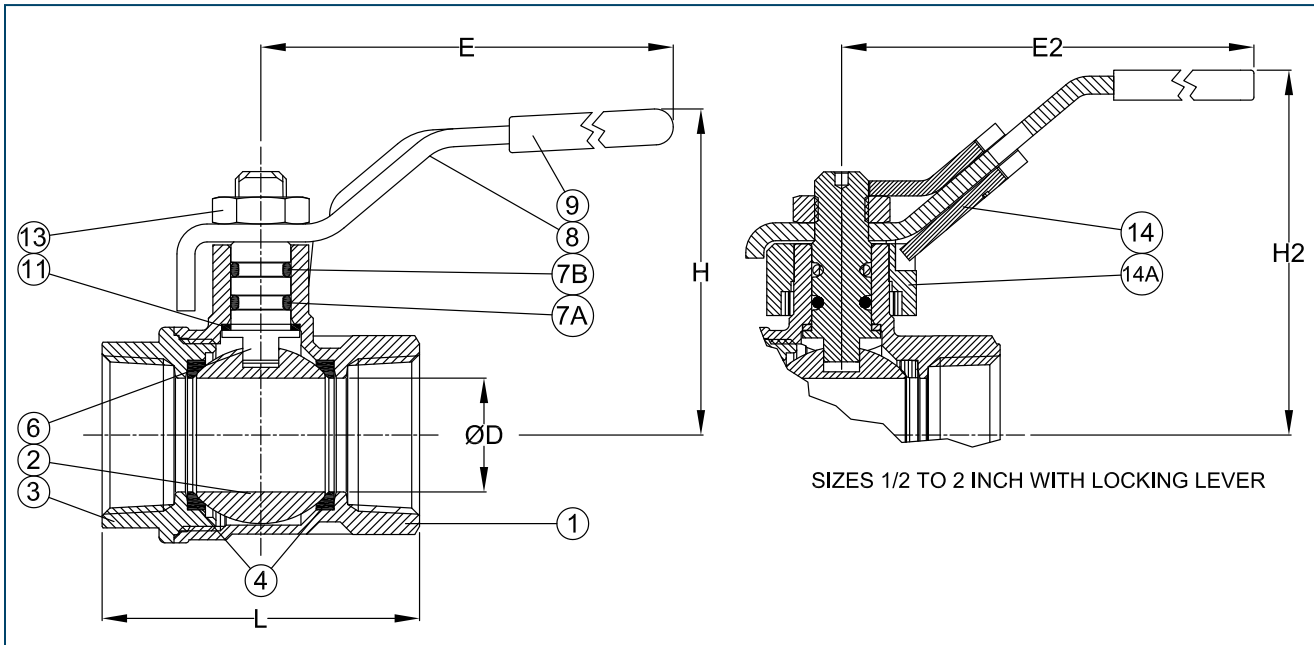

Figure Number Matrix

FNW 400 <u>Lever Size</u>	Kit Codes (Order Separately)		
	<u>LOCKING LEVER</u>	<u>EXTENSIONS</u>	<u>MEMORY STOPS</u>
<u>LEVER TYPES</u> BLANK = STANDARD LL = LOCK LEVER*	1/2 = FNW420LHKBD 3/4 - 1 = FNW420LHKFG 1-1/4 - 1-1/2 = FNW420LHKHJ 2 = FNW420LHKK	1/2 = FNW420SEBD 3/4 - 1 = FNW420SEFG 1-1/4 - 1-1/2 = FNW420SEHJ 2 = FNW420SEK	1/2 = FNW420MSKBD 3/4 - 1 = FNW420MSKFG 1-1/4 - 1-1/2 = FNW420MSKHJ 2 = FNW420MSKK
<u>SIZE CODE*</u> 1/2 = D 3/4 = F 1 = G 1-1/4 = H 1-1/2 = J 2 = K	<u>TEE HANDLES</u> 1/2 = FNW420THKBD 3/4 - 1 = FNW420THKFG	<u>OVAL HANDLES</u> 1/2 = FNW420OHKBCD 3/4 - 1 = FNW420OHKFG 1-1/4 - 1-1/2 = FNW420OHKHJ 2 = FNW420OHKK	

* For standard 1/4" & 3/8" valves, use models FNW420B and FNW420C. For 1/4" & 3/8" valves with locking levers, use models FNW420LLB and FNW420LLC. The lockout collar can easily be converted to the OSHA style lockout by removing the handle, turning the collar 180 degrees and then reattaching the handle.

2 PC FULL PORT 600 WOG w/THREADED ENDS



Standard Materials

Ref. No.	Description	Material	Qty
1	Body	Brass CW 617N UNI EN 12165	1
2	Ball	Brass CW 617N UNI EN 12165 (Nickel-Chrome Plated)	1
3	End Cap	Brass CW 617N UNI EN 12165	1
4	Seat	PTFE	2
6	Stem	Brass CW 614N UNI EN 12164	1
7A	Stem O-ring	FKM (Viton®)	1
7B	Stem O-ring	NBR 75 Shore A	1
8	Handle	Steel Fe DD 11 UNI 10111	1
9	Handle Cover	Vinyl	1
10	Thrust Washer	PTFE	1
13	Handle Nut	Zinc Plated Steel 6S	1
14	Locking Pad	Fe P 11 UNI EN 10111	1
14A	Bushing	ZAMA G Zn A14 UNI EN1774	1

Dimensions (inches)

Size	ØD	E	L	H	E2	H2
1/2	0.55	3.78	1.87	1.77	3.78	1.93
3/4	0.75	4.76	2.08	2.22	4.84	2.38
1	0.94	4.76	2.58	2.32	4.84	2.48
1-1/4	1.18	5.94	3.01	2.87	5.94	3.03
1-1/2	1.49	5.94	3.50	3.09	5.94	3.23
2	1.85	6.30	4.05	3.66	6.30	3.72

Cv & Weights

Size	Cv	Wt. (Lbs)
1/2	19	0.35
3/4	34	0.62
1	50	0.91
1-1/4	103	1.53
1-1/2	268	2.17
2	309	3.54

DOC: FNW400BV08 Ver. 6/2009

© 2009 - FNW. All rights reserved.

The FNW logo is a registered trademark of Ferguson Enterprises, Inc.

The contents of this publication are presented for information purposes only, and while effort has been made to ensure their accuracy, they are not to be construed as warranties or guarantees, expressed or implied, regarding the products or services described herein or their use or applicability. All sales are governed by our terms and conditions, which are available on request. We reserve the right to modify or improve the designs or specifications of our products at any time without notice. Always verify that you have the most recent product specifications or other documentation prior to the installation of these products.