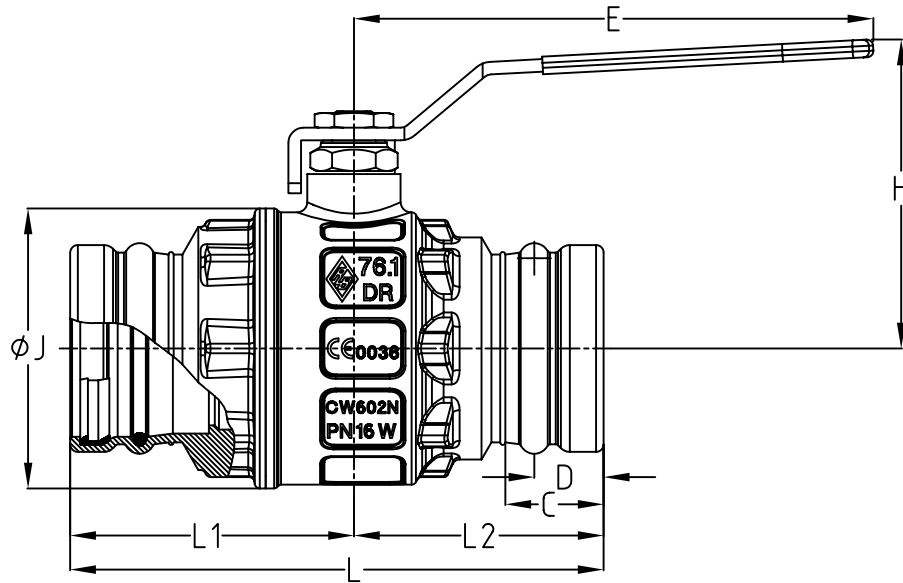
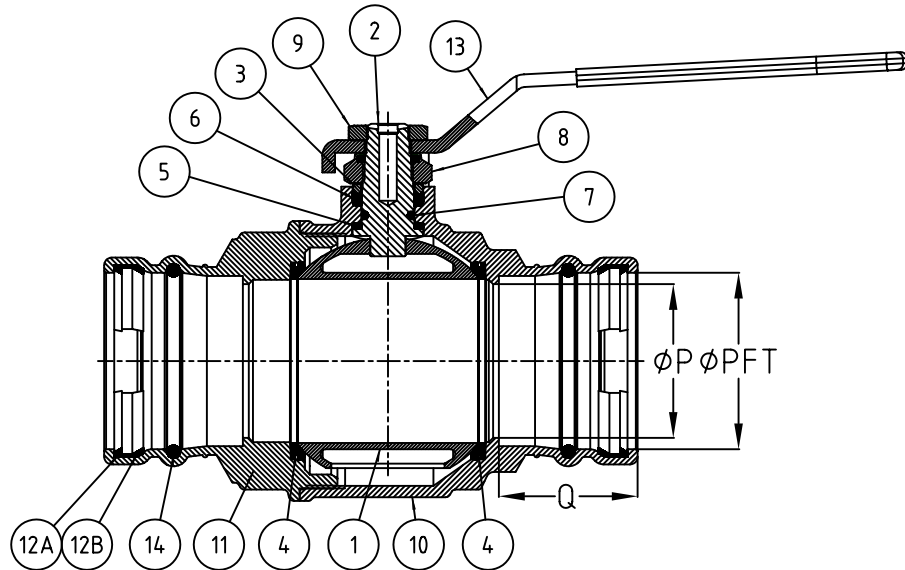

Fig No: FNW430 (XL)



MATERIALS LIST

Ref. No.	Description	Material	Qty
1	Body	Brass CW 602N UNI EN 12165	1
1A	O-Ring	EPDM (EP851)	2
2	Ball	Brass CB 753-S UNI EN 1982 (Nickel-Chrome Plated)	1
3	End Cap	Brass CW 602N UNI EN 12165	1
4	Seat	PTFE	2
6	Stem	Brass CW 614N UNI EN 12164 NP	1
7	Stem Packing	PTFE	1
7A	Stem O-Ring	NBR	1
8	Handle	Steel Fe DD11 UNI EN 10111	1
9	Handle Cover	Plastic	1
10	Thrust Washer	PTFE	1
11	Gland Nut	Steel, Zinc Plate	1
11A	Packing Gland	Brass CW 614N UNI EN 12164	1
12A	Circlip	S235JR UNI EN 10025	2
12B	Backer Ring	Steel, Zinc Plated	2
13	Handle Nut	Steel, Zinc Plate	1



The FNW large body figure 430 press valves (2-1/2" to 4") are designed for installation using crimp tools equipped with XL style jaws.

**CAUTION:** 4" VALVES ARE FOR COPPER PIPE AND COPPER FITTINGS ONLY AND SHOULD NOT BE USED ON BRASS FITTINGS OR ADAPTERS

DIMENSIONS

Size	C	D	E	H	ØJ	L	L1	L2	ØP	ØPFT	Q
2-1/2	1.54	1.08	8.07	5.08	4.37	8.33	4.43	3.90	2.40	2.50	2.17
3	1.54	1.08	8.07	5.51	5.35	9.07	4.82	4.25	2.87	3.00	2.17
4	1.54	1.08	10.24	6.30	6.54	10.63	5.51	5.12	3.82	4.00	2.56

CODE	W-003	APPROVED BY.	CHECK BY.	DRAWN BY.	DRAWING NO.	MATERIAL	UNIT	DESCRIPTION
<b>FNW™</b>	SIGN	KMC		PEA	F430		INCH	BRASS BODY, FULL BORE BALL VALVES, XL PRESS END, 200 PSI WATER, 2-1/2" to 4"
	DATE	02/26/2007	02/23/2007	10/28/2008	REVISION	02	SCALE	